



# USER MANUAL

## CSMB 1.0

### CT Current Sensor with Modbus output

Copyright © XEMEX

All rights reserved. No part of this publication may be reproduced, stored in a retrieval system, or transmitted, in any form or by any means, electronic, mechanical, photocopying, recording or otherwise, without prior written permission of the publisher.

**E** info@xemex.eu  
**T** +32 (0)3 201 95 95  
**F** +32 (0)3 201 95 99  
**W** www.xemex.eu

**NL** Burgemeester Burgerslaan 40  
5245 NH 's-Hertogenbosch  
**BE** Metropoolstraat 11a  
B2900 Schoten

**BTW** 0458.522.364  
**OND. NR.** 458.522.364  
**IBAN** BE56 1735 0211 4388  
**BIC-SWIFT** RABO NL2U

---

**DOCUMENT INFO**

Version: 1.3  
Status: Reviewed  
Version date: 8/02/2023  
Filename: User manual - CSMB 1.0.docx  
Number of pages: 13

---

**HISTORY CHANGES**

VERSION	DATE	DESCRIPTION
1.0	19/04/21	Initial version
1.1	21/05/21	New document layout
1.2	10/05/22	RS485: A(+) & B(-)
1.3	25/07/22	Added units in Modbus memory map
1.4	08/02/23	Description LEDs

---

**TABLE OF CONTENTS**

<b>1</b>	<b>INTRODUCTION</b>	<b>4</b>
1.1	Scope	4
1.2	Target group	4
1.3	Intended usage	4
1.4	Technical assistance	4
1.5	Used symbols	4
1.6	Safety precautions	5
<b>2</b>	<b>TECHNICAL DESCRIPTION</b>	<b>6</b>
<b>3</b>	<b>TECHNICAL SPECIFICATIONS</b>	<b>7</b>
3.1	Environmental conditions	7
3.2	DC Power Interface	7
3.3	Cable Specifications	7
3.4	Metering Interface	7
3.5	Modbus Interface	7
3.6	User Interface	8
3.7	Screw terminals	8
3.8	Wire stripping	8
3.9	Modbus registers	9
3.10	Modbus Properties	10
3.10.1	Physical LAYER properties	10
3.10.2	Data Link LAYER properties	10
3.10.3	Application LAYER properties	10
<b>4</b>	<b>INSTALLATION INSTRUCTIONS</b>	<b>11</b>
4.1	Guidelines for safety and installation	11
4.2	Mounting	11
4.3	Electrical wiring	11
4.4	NOTES	11
<b>5</b>	<b>OPERATING INSTRUCTIONS</b>	<b>12</b>
5.1	PWR - POWER Status LED – Yellow LED	12
5.2	MB – MODBUS Status LED – Red LED	12
5.3	CS – Current Sense status LED – Green LED	12
<b>6</b>	<b>CLEANING</b>	<b>13</b>
<b>7</b>	<b>LIFTING AND CARRYING</b>	<b>13</b>
<b>8</b>	<b>MAINTENANCE AND SERVICE</b>	<b>13</b>

## 1 Introduction

### 1.1 Scope

This manual is applicable to CSMB 1.0, a CT Current Sensor with Modbus output. It describes the specifications, installation and operation of the product. Please read this document carefully before installation and operating.

### 1.2 Target group

The installation and the operation of this device and any maintenance must be carried out by a qualified person in accordance with specific local standards and safety regulations.

### 1.3 Intended usage

The CSMB is only to be used for measuring electrical current and shall operate within the specified values only.

### 1.4 Technical assistance





In case technical assistance is needed, contact Xemex NV:

XEMEX NV  
Metropoolstraat 11a  
B-2900 Schoten  
Belgium

Tel: +32 201 95 95  
E-mail: [support@xemex.eu](mailto:support@xemex.eu)

### 1.5 Used symbols

Following symbols are used in this document and/or are marked on the product:

	Alternating current
	Three-phase alternating current
	Equipment protected throughout by DOUBLE INSULATION or REINFORCED INSULATION
	Caution, possibility of electric shock
	Caution

## 1.6 Safety precautions:



### **DANGER — HAZARDOUS VOLTAGES**

WARNING - These installation/servicing instructions are for use by qualified personnel only. To avoid electrical shock, do not perform any servicing other than that contained in the operating instructions unless you are qualified to do so.

Always adhere to the following checklist:

1. Only qualified personnel or licensed electricians should install the Xemex CSMB. The mains voltages of 120 Vac to 600 Vac can be lethal!
2. Follow all applicable local and national electrical and safety codes.
3. Install the meter in an electrical enclosure (panel or junction box) or in a limited access electrical room.
4. Verify that circuit voltages and currents are within the proper range for the meter model.
5. Use current transformers (CTs) with built-in TVS with a dielectric strength of at least 3.5KV 50Hz 1min and a work voltage of 660V. Do not use current output (ratio) CTs such as 1 amp or 5 amp output CTs: they will destroy the meter.
6. Ensure that the CTs are placed behind fuses or circuit breakers.
7. Equipment must be disconnected from the HAZARDOUS LIVE voltages before access.
8. Before applying power, check that all the wires are securely installed by tugging on each wire.
9. Do not install the CSMB where it may be exposed to temperatures below  $-25^{\circ}\text{C}$  or above  $75^{\circ}\text{C}$ , excessive moisture, dust, salt spray, or other contamination. The meter requires an environment no worse than pollution degree 2 (normally only non-conductive pollution; occasionally, a temporary conductivity caused by condensation must be expected).
10. Do not drill mounting holes in the device. Click the module on a DIN Rail instead.
11. If the CSMB is installed incorrectly, the safety protections may be impaired.

## 2 Technical description

The Xemex CSMB device is a Current Transformer current metering device with a Modbus Interface. It has following interfaces:

- DC Power Interface
- RS485 Communication Interface
- User Interface
- Current Transformers (CT) Interface

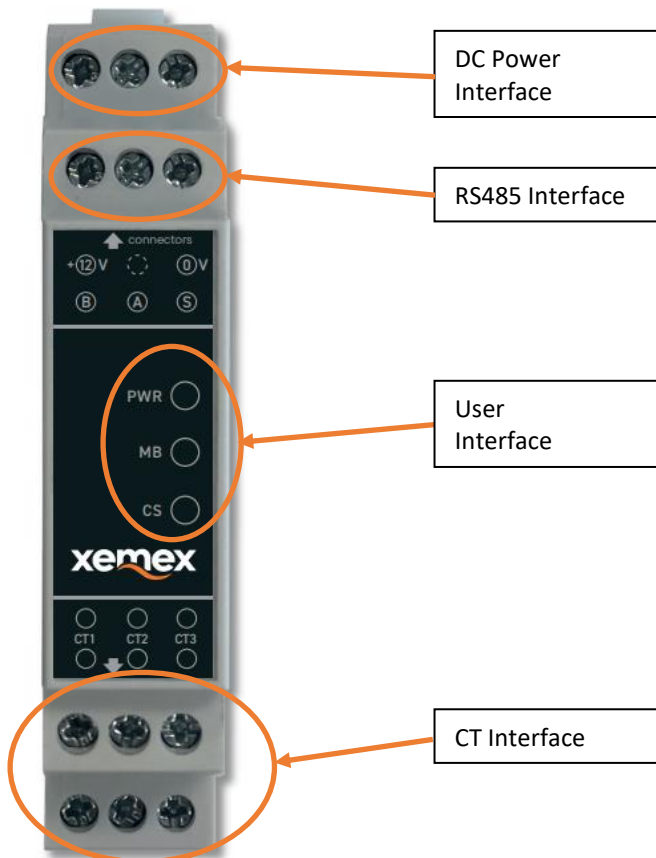

The CSMB measures the RMS current values of the three current transformer inputs over a period of 1 second.

At the end of the measurement cycle the new RMS values are stored in the corresponding Modbus registers (see below).

This process continuously repeats every second.

### 3 Technical specifications

#### 3.1 Environmental conditions

Protection class	II
Operating temperature	-25 °C - +75 °C
Storage temperature	-40 °C - +85 °C
Relative humidity	< 75 % year's average at 21 °C < 95 % less than 30 days/year, at 25 °C
Pollution Degree	2
Altitude	< 2000m
Application area	Residential, Indoors in suitable meter cabinet

#### 3.2 DC Power Interface



**DANGER**  
Use SELV power supply only!  
Risk of serious injuries or death and/or at least product damage!

Connector	Screw terminal connector for 0V and +12V DC
Voltage range:	12V DC, -50%, +10%
Max current consumption:	50 mA
Max cable length:	100 meter
Cable location:	indoor + outdoor
Reverse polarity protection:	yes

#### 3.3 Cable Specifications

Preferably armored twisted pair with drain wire. Section 0,20 ... 0,50 mm<sup>2</sup>. Use wires of same pair to connect B and A, wires from the other pair to +12V and 0V.  
Example of cable type: Belden 3107A

#### 3.4 Metering Interface



Use current transformers (CTs) with built-in TVS with a dielectric strength of at least 3.5KV 50Hz 1min and a work voltage of 660V. Do not use current output (ratio) CTs such as 1 amp or 5 amp output CTs: they will destroy the meter.  
Ensure that the CTs are placed behind fuses or circuit breakers.

Connector	Screw terminal connectors for max 3 Current Transformers
Measuring principle	Current measurement by Current transformer
Current range	1A ... 80A (if CT ratio = 2000)
CT ratio	2000 (default)
Input impedance	20 Ohm
Accuracy	Typically <5 % at 23 °C
Max Cable length	1 meter

#### 3.5 Modbus Interface

Connector	Screw terminal connector for A (+), B (-) and Shield
-----------	--

Bus termination	120 Ohm, switchable on/off
Protocol	Modbus RTU over RS485
Max cable length:	100 meter
Cable location:	indoor + outdoor

### 3.6 User Interface

Power indicator	Yellow LED
Current indicator	Green LED
Modbus indicator	Red LED

### 3.7 Screw terminals

#### Single-deck terminal block - Right side - Pitch 5mm - 3 poles

##### GENERAL INFORMATION

pitch:	5 mm
housing height:	15,30 mm
housing depth:	9.5 mm
dimensional class:	medium
wire section:	2.5 mm <sup>2</sup> / 14 AWG
clamp opening size:	2.7 × 2.7 mm
wire stripping:	max 7 mm
operating temperature:	-40°C + +130°C

##### ELECTRICAL CHARACTERISTICS

current:	16A
voltage:	250V
test voltage:	2 kVrms/60s

##### MECHANICAL CHARACTERISTICS

screw:	M3
max. torque:	0.5 Nm / 4.5 in.lbs

##### APPROVALS DATA



	EN 60998-1	-	UL 1059
current:	16A	-	15A factory / 15A field
voltage:	250V	-	300V
wire section:	2.5mm <sup>2</sup>	-	14+30AWG
torque:	0.5Nm	-	4.5Lb-in
FILE:	CA02.01614	-	E178356

##### MATERIALS

housing:	PA - UL 94 V0
screw:	Galvanized steel
clamp/spring:	Nickel copper alloy
terminal:	Tin-plated copper alloy

##### AVAILABLE COLOURS



other colours: upon request

### 3.8 Wire stripping

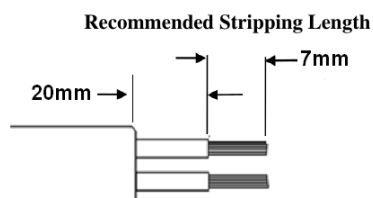



### 3.9 Modbus registers

The registers below are accessible by the Modbus function code 03 – *Read Holding Register*.

The registers marked in blue can also be written by the Modbus function 06 – *Write Single Register*.

Updated settings become active after rebooting the device by writing the Reboot register.

Reg address	Register length (# of u16)	Contents	Unit	Data type
0x4000	2	Serial Number (last 8 digit of LDN)	-	HEX
0x4002	1	Device code	-	HEX
0x4003	1	Modbus device address	-	UINT16
0x4004	1	RS485 baudrate low	-	UINT16
0x4005	2	Protocol version	-	Float ABCD
0x4007	2	Software version	-	Float ABCD
0x4009	2	Hardware version	-	Float ABCD
0x400B	1	Meter amps	A	UINT16
0x400C	1	CT ratio	A	HEX
0x400D	1	RS485 line settings (default 8E1 = 0x24 / 8N1 = 0x04)	-	UINT16
0x400E	1	Enable / disable line termination	-	UINT16
0x400F	1	RS485 baudrate high	-	UINT16
0x500C	2	RMS current CT1	A	Float ABCD
0x500E	2	RMS current CT2	A	Float ABCD
0x5010	2	RMS current CT3	A	Float ABCD
0xFFFF	1	Reboot	-	UINT16

## 3.10 Modbus Properties

### 3.10.1 Physical LAYER properties

- Baud rate:
  - 1200 ... 115200
  - default value is 9600 baud.
- Line setting:
  - 8N1 (line settings register value = 0x04) , 8E1 (line settings register value = 0x24)
  - default value is 8E1.
- Enable/disable line termination resistor:
  - default value is enabled.

### 3.10.2 Data Link LAYER properties

- Modbus device address
  - 1 .. 247
  - default address is 1.

### 3.10.3 Application LAYER properties

Modbus RTU server which supports following Modbus Function Codes:

- Read Holding Register
- Write Single Register

## 4 Installation instructions

### 4.1 Guidelines for safety and installation



This installation guide must be consulted in all cases when manipulating parts which are marked with the Caution symbol.

The installation and the operation of this device and any maintenance must be carried out by a qualified person in accordance with specific local standards and safety regulations.



Caution: never open the secondary circuit of a Current Transformer while current is flowing through the primary circuit!

If the secondary circuit is opened when primary current is flowing, then the voltage will go to a very high value, possibly causing electrical arcing and/or electrical shock to service personnel. Therefore CT's with internal TVS must be used.

Failing to obey the "Guidelines for safety and installation", the guarantee no longer applies.

### 4.2 Mounting

Mount the device in a DIN rail cabinet.

### 4.3 Electrical wiring

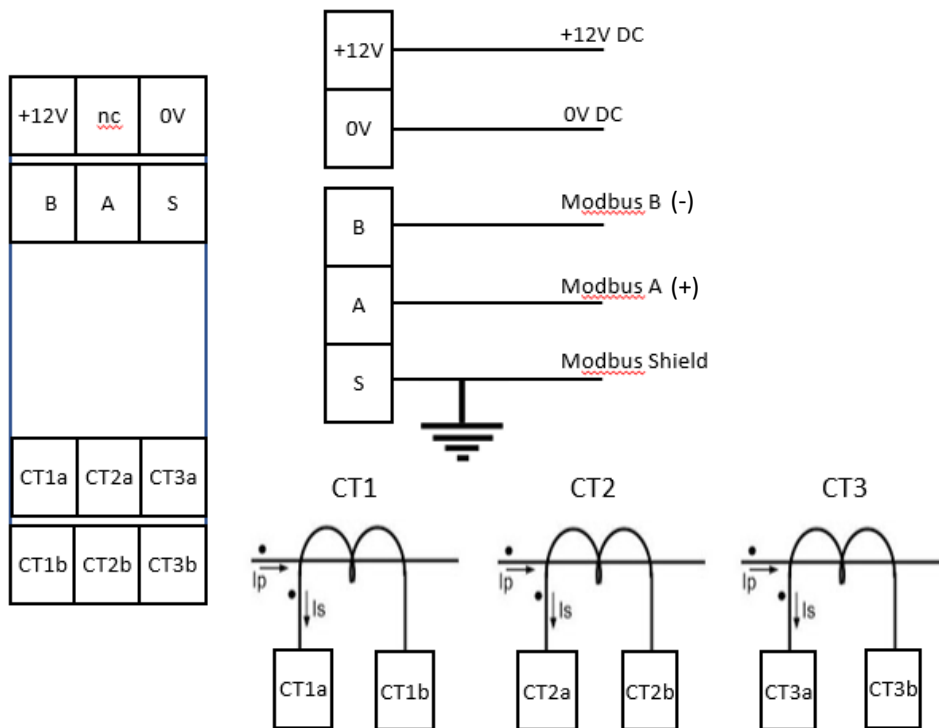

### 4.4 NOTES



The Modbus Shield must only be connected at the CSMB side and not at the Modbus master side. The Modbus Shield connection is also connected to the protected earth of the building.

## 5 Operating instructions

After installation and applying DC power the device starts automatically measuring the RMS current values flowing through the connected current transformers.

A connected Modbus master can request these values by reading the corresponding Modbus registers.

The CSMB device gives visual feedback by its 3 Status Indicators:

### 5.1 PWR - POWER Status LED – Yellow LED

- Not lit: CSMB device is not powered
- Blinking: CSMB device is powered, but voltage is below 6 Volt
- Lit: CSMB device is powered, voltage is above 6 Volt

### 5.2 MB – MODBUS Status LED – Red LED

- Not lit no data received within the last 10 seconds.
- Blinking data received, but no valid\* modbus request received within the last 10 seconds.
- Continuously lit valid\* modbus request received within the last 10 seconds.

Valid\* = CRC verified frame for own address

### 5.3 CS – Current Sense status LED – Green LED

- Blinks with a period of 1 second, its duty cycle indicates the current level.

## 6 Cleaning

Clean the unit with a slightly damp cloth and mild detergent.

## 7 Lifting and carrying

Use care when lifting and carrying the product.

## 8 Maintenance and Service

There are no serviceable parts inside.

**End Of Document.**